

96 Way LC FibrePlus Patch Panel

Datasheet: GD062439v6

APPLICATION

The Brand-Rex 96 Way FibrePlus Patch Panel offers a superior solution for management of Fibre in data centres and telecoms rooms. This is a unrivalled product, designed with an emphasis usability and accessibility yet still allowing for up to 96 connections per 1U. This exceptional fibre count makes the panel a market leading product ideally suited to high density applications. The panels are supplied with pre-installed LC adaptors and accessories as standard and its shallow depth allows it to be installed within most conventional racks & wall mounted enclosures.

FEATURES

- Suitable for up to 96 LC fibre connections.
- Complete Fibre Management Kit included.
- Sliding tray for easy access complete with quick release fastenings.
- Compatible with Blolite & standard fibre cables.
- Rear panel offers a choice of apertures to suit a variety of glanding arrangements.
- Rear Panel can be customized by the addition of separate glanding plates.
- Raised slots in the panel base allow for alternative configurations and offer additional securing points for incoming cables.
- Suitable for mounting in shallow enclosures due to the adjustable mounting brackets allowing a minimum depth of 237mm.
- Front panel includes a port identification strip.
- Singlemode and Multimode options available.



FPCC1SXSM96LC2

ORDER INFO

Brand-Rex Part Number	Item Description	Colour	Weight per Item (nom)	Qty per Pack
FPCC1SXSM96LC2	96 Way LC Singlemode FibrePlus Panel	Black	3kg	1
FPCC1SXMM96LC2	96 Way LC Multi mode FibrePlus Panel	Black	3kg	1

96 Way LC FibrePlus Patch Panel

Datasheet: GD062439v6

Brand-Rex | a LEVITON company

PHYSICAL CHARACTERISTICS

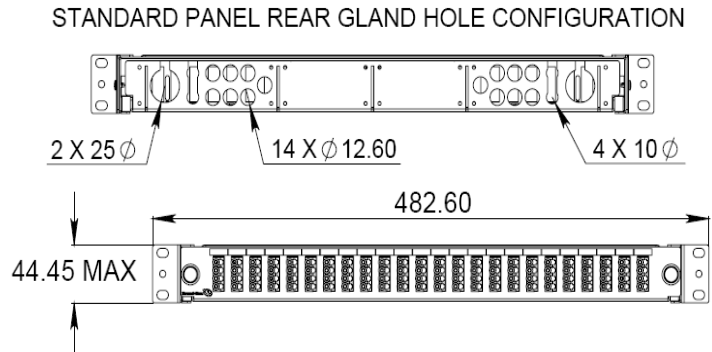
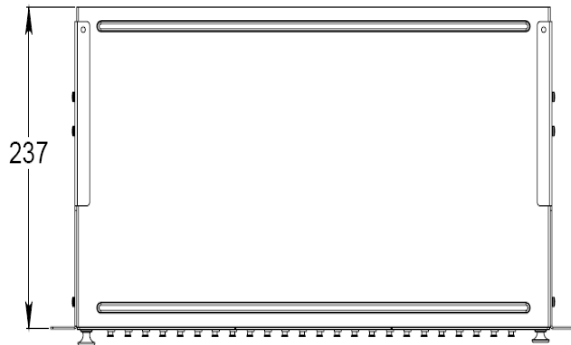

MATERIALS

- Panel manufactured from high quality powder coated mild steel RAL9005 (Black)
- Press Lock Studs- Nylon
- Cable Management- Nylon
- Adapter - Polycarbonate/zirconia ceramic sleeves

APPLICATIONS

- Small, Corporate and internal Data centres
- Conventional, Backbone cabling installations

PACKAGING

- Panel Panels are individually boxed complete with adaptors and internal fibre management accessories kit as follows.

INSTALLATION

- Panel designed for 2 x 48 fibre cables
- Panel can accommodate 4 x 24 Fibre Cables using a 25mm Cable gland with 4 x 8mm duct manifold. For part numbers please see Compatible products below - For alternative cable type or configurations please contact Brand Rex for details
- Suitable for Data Network applications where panel space is at a premium.
- Suitable for use in Brand-Rex approved 19" cabinets.
- Suitable for use with approved Brand-Rex Patch FO cords, panels and cable management products.

ACCESSORIES KIT (SUPPLIED WITH PANEL)

- 8 x adhesive management rings
- 1 x laser warning label
- 4 x 24 way stackable splice bridges
- 2 x splice bridge covers
- 2 x adhesive splice bridge mounting pads
- 2 x M25 glands & lock nuts for cable Ø8 -13mm

"Brand-Rex is dedicated to designing, developing and manufacturing sustainable high performance structured cabling and speciality cabling solutions"

The information contained in this document is valid and correct at the time of issue. Brand-Rex reserves the right to modify details without notice in light of subsequent standard/specification changes and ongoing technical developments.